

SM110

Diaphragm safety valve for closed heating systems

Product specification sheet

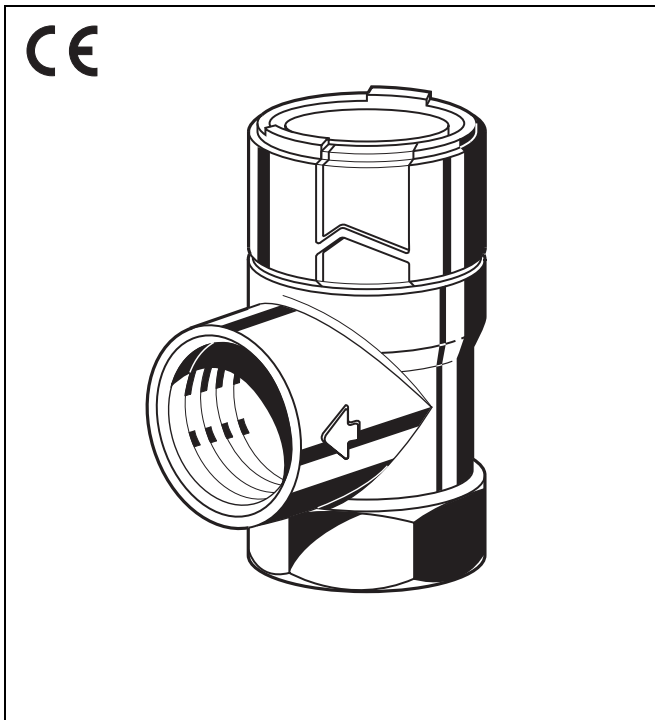

Construction

The safety valve comprises:

- Angled housing
- Adjustment spring
- Diaphragm
- Security cap with part label

Materials

- Brass housing
- Spring steel adjustment spring
- High grade synthetic material security cap
- Hot water resistant elastomer diaphragm

Application

Membrane safety valves of this type are used to protect closed heating systems according to EN 12828.

In accordance with statutory requirements, the diaphragm safety valve is preset to the required fixed set pressure by the manufacturer and is sealed with an embossed security cap marked with the test badge and pressure rating to prevent unauthorised tampering with the setting. Subsequent alteration of the setting is not permitted and is impossible without destroying the security cap. The preset pressure is embossed on the security cap.

Special Features

- Certified to Pressure Equipment Directive 97/23/EC, Reference No. CE 0036
- Standardised discharge connection
- With lifting device
- Protected against subsequent changing of the default settings

Range of Application

The membrane safety valve is only suitable to drain the following media from closed heating systems according to EN 12828 for protection against exceeding pressure

Medium

Water or glycol-water mixture, according to VDI 2035

Liquids of the fluid group 1 and 2 (pressure device guideline, item 9) which do not affect the materials used.

Technical Data

Installation position	Horizontal with safety cap pointing up
Opening pressure	Factory preset to 1.5, 2.0, 2.5, 3.0, 4.0 or 6.0 bar
	Subsequent alteration of the setting is not permitted and is impossible without destroying the security cap
Operating temperature	Max. 120 °C
Connection size	Internal thread on inlet 1/2", 3/4", Internal thread on outlet 1/2", 3/4", 1" External thread on inlet 1/2" with internal thread on outlet 3/4"
	Valve size is defined by the size of the inlet connection

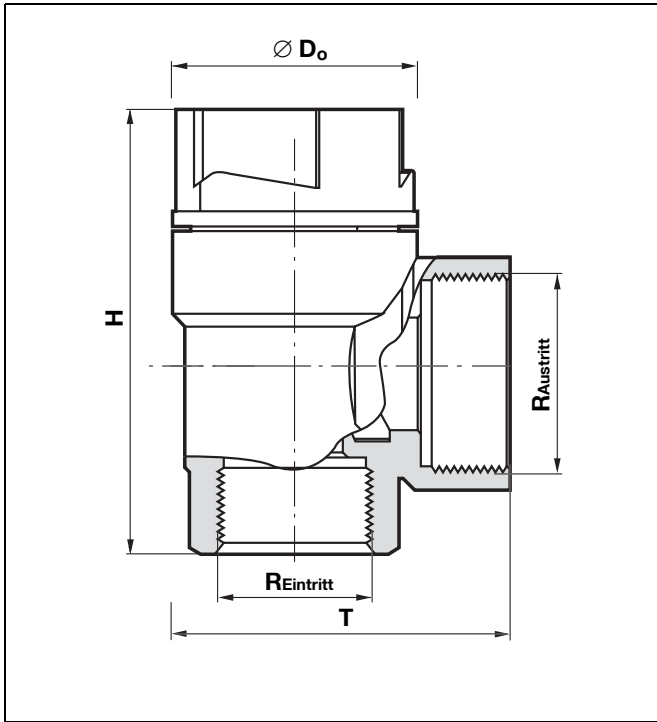

Method of Operation

Diaphragm safety valves of this type are directacting safety valves in which the disc is pushed up by the pressure from the system against a spring which is holding the valve closed. If the opening force exceeds the force exerted by the spring, then the valve disc is lifted off the valve seat and the valve discharges the medium. In accordance with the requirements of the standard, the full discharge capacity of the valve will be achieved when the system pressure climbs to no more than 10% above the set pressure of the valve. Full shutoff must be achieved if the system pressure falls to below 80% of the nominal set pressure of the valve. For valves rated up to 3.0 bar, the closing pressure can be taken as 0.6 bar minimum.

Options

OS.-No.	Set pressure	Connection size Inlet	Connection size Outlet
SM110- 1/2ZA2.5	2.5 bar	Rp1/2" IG	Rp1/2" IG
SM110- 1/2ZA3.0	3 bar	Rp1/2" IG	Rp1/2" IG
SM110- 1/2A1.5	1.5 bar	Rp1/2" IG	Rp3/4" IG
SM110- 1/2A2.0	2.0 bar	Rp1/2" IG	Rp3/4" IG
SM110- 1/2A2.5	2.5 bar	Rp1/2" IG	Rp3/4" IG
SM110- 1/2A3.0	3.0 bar	Rp1/2" IG	Rp3/4" IG
SM110- 1/2A4.0	4.0 bar	Rp1/2" IG	Rp3/4" IG
SM110- 1/2A6.0	6.0 bar	Rp1/2" IG	Rp3/4" IG
SM110- 3/4ZA2.5	2.5 bar	Rp3/4" IG	Rp3/4" IG
SM110- 3/4ZA3.0	3.0 bar	Rp3/4" IG	Rp3/4" IG
SM110- 3/4A1.5	1.5 bar	Rp3/4" IG	Rp1" IG
SM110- 3/4A2.5	2.5 bar	Rp3/4" IG	Rp1" IG
SM110- 3/4A3.0	3.0 bar	Rp3/4" IG	Rp1" IG
SM110- 3/4A4.0	4.0 bar	Rp3/4" IG	Rp1" IG
SM110- 1/2AA1.5	1.5 bar	Rp1/2" AG	Rp3/4" IG
SM110- 1/2AA2.0	2.0 bar	Rp1/2" AG	Rp3/4" IG
SM110- 1/2AA3.0	3.0 bar	Rp1/2" AG	Rp3/4" IG

Connection size Inlet	R	1/2" IG	3/4" IG	1/2" IG	3/4" IG	1/2" AG
Connection size Outlet	R	1/2" IG	3/4" IG	3/4" IG	1" IG	3/4" IG
Dimensions (mm)	H	60	62	60	62	60
	Ø D _o	33	33	33	36	33
	T	32	46	46	46	46
Weight	g	135	145	140	150	140
Maximum permissible heat input (kW)		50	100	50	100	50
TÜV Approval Nos.		-	-	TÜV · SV · ..* - 2017 · 13 · H · 2,5bar TÜV · SV · ..* - 2017 · 13 · H · 3bar		

..* valid Approval No.

Only the products with an outlet diameter larger than the inlet diameter are TÜV-certified.

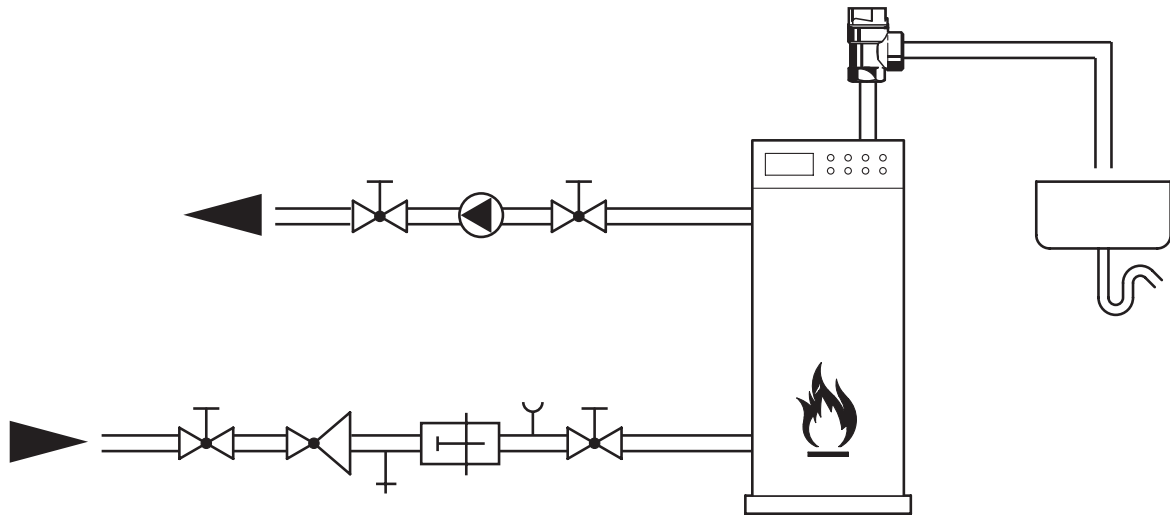
Installation Example**Installation Guidelines**

- Mount the safety valve at the highest point of the heat generator or in its immediate vicinity on the flow line
- The installation must be carried out so that:
 - o no shut-off fittings, restrictions or strainers are located between safety valve and heat generator
 - o good access is provided for service and maintenance
 - o that the safety valve is positioned above the heat generator
 - o that between the safety valve and heat exchanger a max. 1 m long straight connection line with the size of the inlet diameter is installed
- The safety valve must be mounted so that in its installed condition no external forces act on it
- The discharge line must be performed to the size of the safety valve outlet diameter and may not have more than 2 elbows and or be longer than 2m
- The discharge line must be installed with an incline

Typical Applications

Membrane safety valves are installed according to their specification upstream from heat generators.

The following is a typical application:

- closed heating systems

Maintenance

We recommend conducting the measures listed below regularly and to enter into a maintenance agreement between operating company and installation company.

	Operation	Interval	Carried out by
Inspection	Function check by verifying the response: While the system is operating, briefly open the safety valve by turning the cap. After closing the cap the valve must close again the backed up water drain completely.	Every six months	User or specialist
Maintenance	If a malfunction is detected, a repair can be attempted by opening and closing the cap several times. A replacement is necessary if this action is not successful.	Annually	Specialist

Automation and Control Solutions

Honeywell GmbH
Hardhofweg
D-74821 Mosbach
Phone: (49) 6261 810
Fax: (49) 6261 81309
<http://europe.hbc.honeywell.com>
www.honeywell.com

Manufactured for and on behalf of the
Environmental and Combustion Controls Division
of Honeywell Technologies Sàrl, Rolle, Z.A. La
Pièce 16, Switzerland by its Authorised Repre-
sentative Honeywell GmbH

EN0H-1366GE23 R0509
Subject to change without notice
© 2009 Honeywell GmbH

Honeywell