



Lifting units

Flexible solutions for waste water and sewage disposal



Made in Germany

Table of contents

Areas of application for lifting units	Page 3
Lifting units for waste water	Page 4
Lifting units for sewage water	Page 8
The energy requirement of lifting units	Page 14
Comfort control ZPS	Page 15
The Zehnder cutting system	Page 16
Dimensioning and configuration	Page 17
Service and maintenance	Page 17
FAQ - 11 frequently asked questions about our lifting units	Page 18
Individual solutions	Page 19
References	Page 20
Checklist for the configuration of lifting units	Page 22
Application overview	Page 23



Areas of application for lifting units

Detached houses

In detached houses, single lifting units are used for pumping sewage water from underneath the flood level from shower cabs, washbasins, washing machines etc. Likewise, suitable lifting units with integrated cutting system can shred as well as suitably dispose faeces in the sewage water.



Apartment blocks and trade facilities

Apartment blocks require more complex lifting units. For such cases, twin-pump lifting units with alternating operating mode and at the same time, simultaneous operation of both pumps under peak-load conditions assure high reliability. Twin-pump lifting units are the optimal solution for both multi-apartment houses, hotels, gastronomic premises and trade facilities.



Public buildings and large properties

Twin-pump lifting units for large objects are characterized by high flow capacity and properly dimensioned tank volume to receive big water volumes and if needed, serve as emergency backup reserve in case of failure. Likewise, our units can be used for remote control by means of the facility management as they immediately indicate possible failures. In this way, high operational reliability is ensured.





Lifting units for waste water without faeces

The sewage lifting units without fed faeces are subject to DIN 12050-2.

For such lifting units, various models of Zehnder Pumpen are on option, among them several models for aggressive media to be pumped. Installing special pumps, sewage water from condensing boilers and softening systems can be handled as well. Short-time operation with hot waste water up to 90°C is also possible.

The collecting tank is aerated and vented either through an incorporated activated carbon filter including overfilling protection or aerating and venting lines laid to outside as commonly used in larger lifting units.

As regards single units, the level is controlled by a built-in float switch, whilst with twin-pump lifting units, a comfort controller featuring both a pneumatic level detection and an integrated alarm trigger unit are attached to.



Waste water disposal from the washing machine

Series SWH

- pre-assembled - pump and control already integrated
- integrated high water alarm signal
- double safety by 2nd float (alarm float)
- all connections prepared, all connection pieces included in scope of delivery
- easy to maintain due to pump attached to the cover
- special version S-SWH: pumping of slightly acid condensate, aggressive or saline media (max. 15% salt content)



P ₂	130 up to 430 W
Q _{max}	8,0 up to 14,0 m ³
H _{max}	6,0 up to 11,0 m
Pressure outlet	1 ¼" IG
Solids handling	10 mm
Weight	5 up to 6 kg
Inlet connections	DN 50, DN 40, hose nozzle



Series UFB 200

- pre-assembled - pump and control already integrated
- all connections prepared
- integrated siphon to avoid unpleasant odours
- special inlets possible ex works
- special version S-UFB: pumping of slightly acid condensate, aggressive or saline media (max. 15% salt content)

P ₂	130 up to 430 W
Q _{max}	7,0 up to 11,0 m ³
H _{max}	7,5 up to 11 m
Pressure outlet	1 ¼" AG
Solids handling	10 up to 30 mm
Weight	6,1 up to 8 kg
Inlet connections	DN 50 (DN 70 / DN 100 optional)

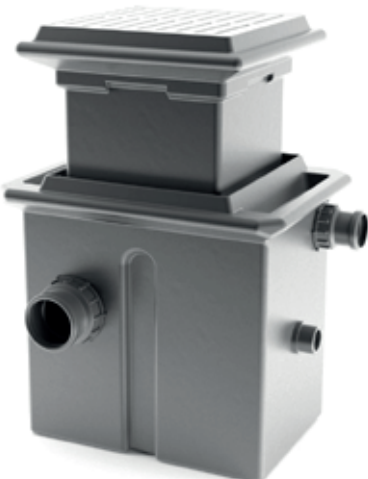

Series SWH 500

- available as single and double system
- ready for connection
- double sealing by mechanical seal and shaft seal ring
- briefly up to 90°C medium temperature

P ₂	210 up to 430 W
Q _{max}	11,0 m ³
H _{max}	11,0 m
Pressure outlet	GA 1 1/4"
Solids handling	10 up to 30 mm
Weight	19,5 up to 29 kg
Inlet connections	3 x DN 100, G1 1/2"



Series SWH 500-F

- grease-resistant plastic container and pump technology (no corrosion)
- double sealing by mechanical seal and shaft seal ring
- easy to maintain due to external non-return valve
- briefly up to 90°C medium temperature

P ₂	130 up to 430 W
Q _{max}	10,0 m ³
H _{max}	14,0 m
Pressure outlet	GA 1 1/4"
Solids handling	10 up to 30 mm
Weight	21,5 up to 33 kg
Inlet connections	3 x DN 100, G1 1/2"



Lifting units for faeces-free wastewater at a glance

Type	Art.-no.	P ₂ [kW]	U [V]	Hmax [m]	Qmax [m ³ /h]	I _n [A]	container volume [l]	switching volume [l]	solids handling [mm]
SWH 100	11463	0,13	230	6,0	8,0	1,3	20	8	10
SWH 170	11468	0,43	230	10,0	11,5	3,7	20	8	10
SWH 190	11471	0,43	230	11,0	14,0	3,7	20	8	10
S-SWH 100	11466	0,13	230	6,0	8,0	1,3	20	8	10
S-SWH 170	11470	0,43	230	10,0	11,5	3,7	20	8	10
S-SWH 190	11472	0,43	230	11,0	14,0	3,7	20	8	10
UFB 200/30	11491	0,13	230	7,5	7,0	1,3	20	15	10
UFB 200/35	11513	0,43	230	11,0	11,0	3,7	20	15	10
UFB 200/40	11515	0,43	230	10,0	10,0	3,7	20	15	30
S-UFB 200/30	11498	0,13	230	7,5	7,0	1,3	20	15	10
S-UFB 200/35	11514	0,43	230	11,0	11,0	3,7	20	15	10
S-UFB 200/40	17948	0,43	230	10,0	10,0	3,7	20	15	30
SWH 500/50	11544	0,21	230	7,5	7,5	1,8	117	75	10
SWH 500/65	11546	0,43	230	14,0	9,5	3,7	117	75	10
SWH 500/80	11548	0,43	230	8,5	10,0	3,7	117	75	30
SWH 500/50 Duplex	11545	0,21	230	7,5	7,5	1,8	117	75	10
SWH 500/65 Duplex	11547	0,43	230	14,0	9,5	3,7	117	75	10
SWH 500/80 Duplex	11549	0,43	230	8,5	10,0	3,7	117	75	30
SWH-F 500/30	17454	0,13	230	7,5	7,0	1,3	117	75	10
SWH-F 500/35	17456	0,43	230	11,0	11,0	3,7	117	75	10
SWH-F 500/40	17458	0,43	230	10,0	10,0	3,7	117	75	30
SWH-F 500/30 Duplex	17455	0,13	230	7,5	7,0	1,3	117	75	10
SWH-F 500/35 Duplex	17457	0,43	230	11,0	11,0	3,7	117	75	10
SWH-F 500/40 Duplex	17459	0,43	230	10,0	10,0	3,7	117	75	30





Lifting units for sewage water containing faeces

The stringent technical requirements as laid out in DIN 1250-1, the lifting units for faeces-containing sewage waters are subject to, are not only fulfilled by the Zehnder sewage lifting units, but exceeded in many respects, too.

As for their application and use, these lifting units are not limited. All the Zehnder lifting units for faeces-containing sewage water are equipped with a pneumatically operated level control including open pitot tube. In this way, the switching points of the lifting unit can be individually set on the controller according to the real application conditions.

Depending on the type of unit, differently dimensioned pressure lines are required. Whilst units equipped with a vortex impeller pump demand a pressure line from nominal diameter 80, a pressure line from nominal diameter 32 will do in sewage lifting units completed with cutting system. Therefore, these units are suitable for cost-efficient pressure drainage.

Contrarily to lifting units for faeces-containing sewage water, the ones for “limited use” according to 12050-3 are subject to certain restrictions of application.

Referring to the above mentioned DIN-standard, those units also called mini lifting units, are permitted in installations of second bathrooms or guest-WC below the sewer backflow level flood level without nearby sewage water line. They are able disposing both faeces-containing sewage water and waste water.



Installation example Kompaktboy simplex



Why pot motors made from aluminium pressure die casting are used?

Pot motors allow for compact designs. The heat dissipation through cooling ribs protects from overheat and prolongs considerably the service life of the motor. The high thermal conductivity coefficient of aluminium additionally enhances motor cooling.

Series Kompaktboy

- compact dimensions, space-saving installation also through shaft opening (60 cm)
- ready for connection - connecting pieces, integrated non-return valve (for 3kW external)
- comfort control included in scope of delivery
- high performance
- integrated dynamic pressure measurement for mm-accurate switching points
- all-round connections for easy installation in confined spaces



P_2	1.100 up to 3.000 W
Qmax	49,0 m ³
Hmax	15,0 m
Pressure outlet	DN 100
Solids handling	50 mm
Weight	42 up to 126 kg
Inlet connections Simplex	3 x DN 100, 3 x DN 50, 1 x DN 50/100
Inlet connections Duplex	3 x DN 100, 1 x DN 50, 1 x DN 100/150



Series Kompaktboy SE

- compact dimensions
- vortex pump with robust, adjustable cutting system made of corrosion-resistant special alloy
- ready for connection - connecting pieces, non-return valve included
- comfort control included in scope of delivery
- for long pressure lines (DN 50)
- suitable for pressure drainage
- high performance



P_2	1.700 up to 3.200 W
Qmax	17,0 m ³
Hmax	39,0 m
Pressure outlet	DN 100
Solids handling	cutting system
Weight	64 up to 144 kg
Inlet connections Simplex	3 x DN 100, 3 x DN 50, 1 x DN 50/100
Inlet connections Duplex	3 x DN 100, 1 x DN 50, 1 x DN 100/150

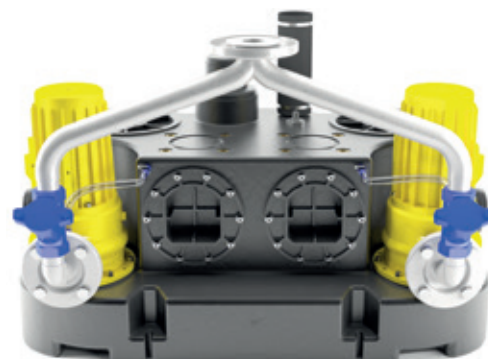



Why tanks of the lifting units are made of PE-HD?

- Chemical resistance to a large variety of acids, bases, alcohols, oils and greases
- Environment-friendly, recyclable synthetic material
- is characterised by high toughness and elongation at break

Series W 80

- completely assembled system with 3.5 m connection cable to the motor and 3.5 m pneumatic hose for the control system
- special dimensions, special inlets and on-site assembly possible
- large container respectively switching volume (tank volume up to 20,000 l realisable)
- blockage-free operation through 80 mm free passage
- comfort control included in scope of delivery
- container can also be made of PP

P ₂	3.000 W
Q _{max}	60,0 m ³
H _{max}	11,0 m
Pressure outlet	DN 100
Solids handling	80 mm
Weight	115 and 205 kg
Inlet connections	DN 150 (further optional)



Series WUZ 100

- completely assembled system with 3.5 m connection cable to the motor and 3.5 m pneumatic hose for the control system
- Special dimensions, special inlets and on-site assembly possible
- large container respectively switching volume (tank volume up to 20,000 l realisable)
- blockage-free operation through 80 mm free passage
- comfort control included in scope of delivery
- container can also be made of PP

P ₂	3.000 up to 7.500 W
Q _{max}	120,0 up to 165,0 m ³
H _{max}	10,0 up to 22,0m
Pressure outlet	DN 100
Solids handling	80 mm up to 100 mm
Weight	210 up to 425 kg
Inlet connections	DN 150 (further optional)



Sewage lifting unit of the Kompaktboy series in detail

- 1 Tank
made from corrosion-resistant PE, capacity 55 l.
- 2 Venting hose
- 3 Motor
up to 3 kW of power
Aluminium pressure die casting case
- 4 Pitot tube
3.5 m pneumatic hose included in the
Scope of delivery
- 5 Inlet, nominal diameter 50 / nominal diameter 100
Additional lateral as well as rear inlets
- 6 Pressure outlet, nominal diameter 100
Adapter flange included in the
Scope of delivery (optionally nominal diameter 80)
- 7 Maintenance opening
of the integrated check valve
- 8 Drainage for check valve

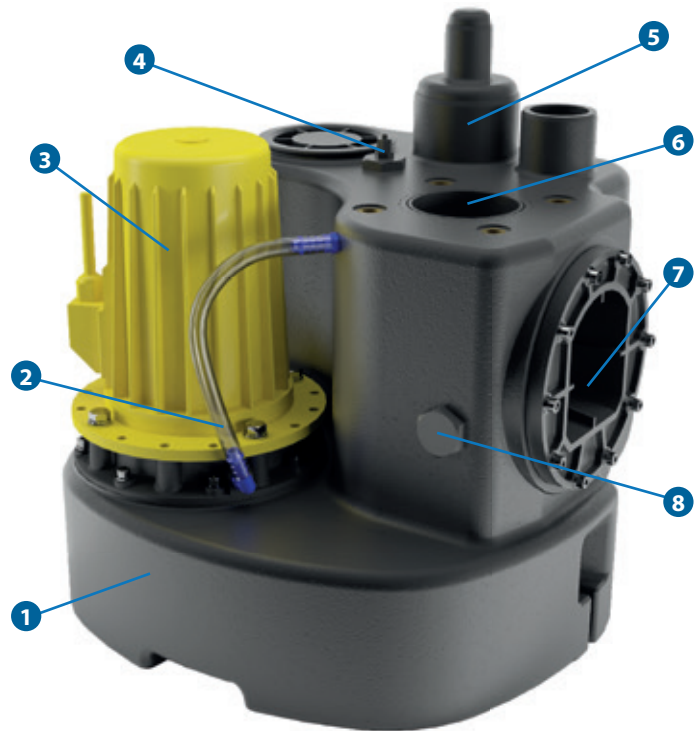

Installation situation

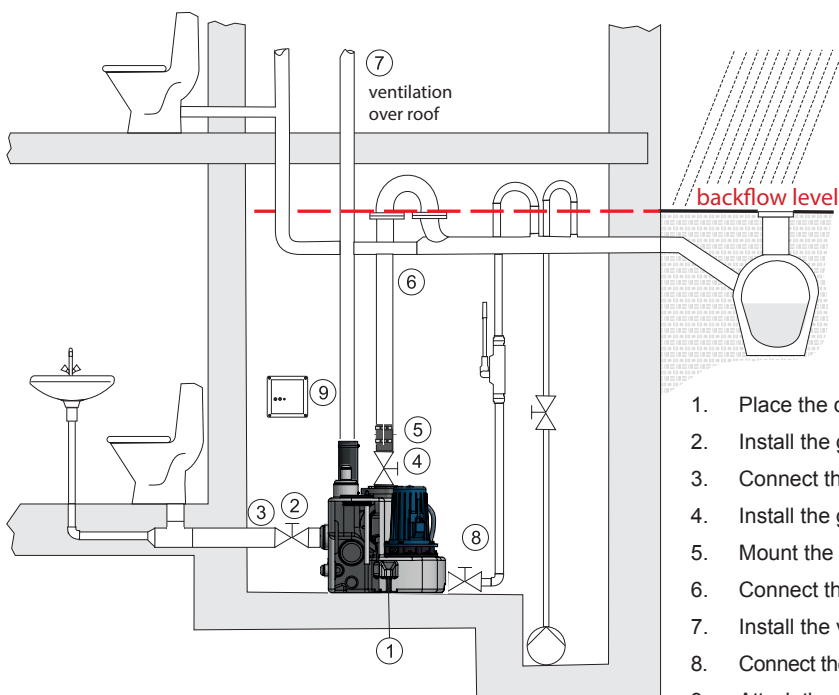

1. Place the collecting tank and secure it against floating
2. Install the gate valve in the feeding line (optional)
3. Connect the feeding line
4. Install the gate valve in the pressure line (optional)
5. Mount the adapter flange, nominal diameter 80
6. Connect the pressure line and lead it over the backflow level
7. Install the venting line
8. Connect the draining line with the manual membrane pump (optional)
9. Attach the control



Microboy Pro

- high performance cutting system (cuts wet tissues and toiletries)
- dry-installed pump with stainless steel cutting system
- 4 additional lateral inlets
- integrated audible alarm
- end-to-end motor shaft for emergency drainage

P ₂	350 W
Q _{max}	7,5 m ³
H _{max}	11,8 m
Pressure outlet	1 1/4" AG
Solids handling	cutting system
Weight	11 kg
Inlet connections	4 x DN 40



Take a look at our high-performance cutting system in action. Simply scan the QR code and start the video.



Lifting units for sewage water

Type	Art.-no.	P ₂ [kW]	U [V]	Hmax [m]	Qmax [m ³ /h]	I _n [A]	container volume [l]	switching volume [l]	solids handling [mm]
Microboy Pro	18190	0,35	230	11,8	7,5	2,5	12	8	cutting system
Kompaktboy Simplex 1,1 W	10428	1,1	230	8,1	41,0	7,6	55	max. 45*	50
Kompaktboy Simplex 1,1 D	10440	1,1	400	8,1	41,0	2,9	55	max. 45*	50
Kompaktboy Simplex 1,5 D	10461	1,5	400	9,9	49,0	3,3	55	max. 45*	50
Kompaktboy Simplex 3,0 D	10466	3,0	400	15,0	35,0	6,2	55	max. 45*	50
Kompaktboy Duplex 1.1 W	17557	1,1	230	8,1	41,0	7,6	150	max. 80*	50
Kompaktboy Duplex 1.1 D	17558	1,1	400	8,1	41,0	2,9	150	max. 80*	50
Kompaktboy Duplex 1.5 D	17559	1,5	400	9,9	49,0	3,3	150	max. 80*	50
Kompaktboy Duplex 3,0 D	17560	3,0	400	15,0	35,0	6,2	150	max. 80*	50
Kompaktboy Simplex SE 71.1 W	17750	1,7	230	22,0	17,0	10,5	55	max. 45*	cutting system
Kompaktboy Simplex SE 71.1 D	17472	1,7	400	22,0	17,0	3,7	55	max. 45*	cutting system
Kompaktboy Simplex SE 71.2 D	17473	1,7	400	25,0	17,0	3,7	55	max. 45*	cutting system
Kompaktboy Simplex SE 71.3 D	17474	3,2	400	35,0	17,0	6,5	55	max. 45*	cutting system
Kompaktboy Simplex SE 71.4 D	17475	3,2	400	39,0	17,0	6,5	55	max. 45*	cutting system
Kompaktboy Duplex SE 71.1 D	17462	1,7	400	22,0	17,0	3,7	150	max. 80*	cutting system
Kompaktboy Duplex SE 71.2 D	17751	1,7	400	25,0	17,0	3,7	150	max. 80*	cutting system
Kompaktboy Duplex SE 71.3 D	17752	3,2	400	35,0	17,0	6,5	150	max. 80*	cutting system
Kompaktboy Duplex SE 71.4 D	17753	3,2	400	39,0	17,0	6,5	150	max. 80*	cutting system
W 80 Simplex	10537	3,0	400	11,0	60,0	6,9	350	175	80
W 80 Duplex	10539	3,0	400	11,0	60,0	6,9	480	270	80
WUZ 100 Simplex 3,0	10545	3,0	400	10,0	120,0	6,9	480	270	80
WUZ 100 Simplex 4,0	10546	4,0	400	13,0	140,0	11,2	480	270	80
WUZ 100 Simplex 5,5	10548	5,5	400	18,0	160,0	12,1	480	270	100
WUZ 100 Simplex 7,5	10549	7,5	400	22,0	165,0	16,9	480	270	100
WUZ 100 Duplexl 3,0	10551	3,0	400	10,0	120,0	6,9	1.000	500	80
WUZ 100 Duplex 4,0	10553	4,0	400	13,0	140,0	11,2	1.000	500	80
WUZ 100 Duplex 5,5	10555	5,5	400	18,0	160,0	12,0	1.000	500	100
WUZ 100 Duplex 7,5	10556	7,5	400	22,0	165,0	16,9	1.000	500	100

* The switching volume depends on the used inlet. The tank of the Kompaktboy series offer various connection options.



The energy consumption of lifting units

The energy consumption of a lifting unit depends on several factors. Both the pump performance and the incoming sewage water volume and consequently, the resulting number of switching operations and run time of the pump, all these factors have their impact on energy consumption.

In addition to the lifting unit, the connected controller consumes energy as well. The Zehnder ZPS comfort controller is based on up-to-date micro-processor technology, consuming about 40 kWh per year in standby mode.

In general, the energy consumption of a lifting unit including controller is not very high due to the low power consumption of the controller and very short run time of the pump. Typical consumers in the household such as refrigerator or TV-set consume a multiple of that energy rate.

Exemplary calculation on basis of the Kompaktboy single unit: 1.1 kW:

According to DIN EN 12056, only that sewage water below the backflow level is allowed to be pumped and disposed above that level. Our exemplary calculation is based on the assumption that the entire incoming sewage water is pumped above the backflow level by the lifting unit.

4 persons household consuming 150 l of sewage water per person / day is summing up to 600 l of sewage water per day.

13 pumping operations per day with a run time of 5 seconds each = 6.6 hours of run time per year.

$$6.6 \text{ h} \times 1.4 \text{ kW (P2)} = 9.24 \text{ kWh}$$

Energy consumption of the pump	9,24 kWh	2,68 €
Energy consumption of the comfort controller	40,30 kWh	11,69 €
Total energy consumption	49,54 kWh	14,37 €

(Basis: 29 Cent per kWh)



Control unit ZPS the intelligent pump control system

ZEHNDER-pump controls are robust, reliable and equipped with a LCD display to monitor the operation data. Furthermore, the control unit has an integrated audible and visible alarm. It is installed in a dry room, e.g. the cellar. The installation in external cabinets outside the house is also possible. Even large distances are enabled by using a small compressor set.

ZPS 1.2

level controlled with dynamic pressure system, float switches or 4-20 mA interface

monitoring of operation on clear text display with signal lights

automatic operation of one mono-phase or three-phase pump

programmable start delay and over-run time

visible and audible alarm with potential-free terminals

polypropylene control box for wall-mounting

monitoring of operation hours, pump starts, power consumption and maintenance intervals

error memory for 64 errors

phase monitoring for three-phase motors

12 languages available

level indicator

high water alarm

24h switch-on

ATEX-mode

service-mode

keylock

ZPS 2.1 - additional features

automatic operation of two mono-phase or three-phase pumps

automatic alternating operation

switchover to standby pump in case of malfunction



Our professional pump control unit ZPS does not only offer simple handling with numerous setting options, but is also very flexible. Standardly supplied for our pumping stations and sewage lifting units, ZPS can also be used for our sewage pumps, waste water pumps and analogical products of other manufacturers.



The Zehnder cutting system

In some of our sewage water lifting units grinder pumps are used. In many cases, the sewage water is loaded with waste, which must not be disposed with the sewage water. Such waste is shredded by the cutting system and disposed without any danger of obstruction. Consequently, our heavy-duty cutting system chops, among others, wet wipes or tampons without any problem.

The cutting gap of our robust cutting system made of corrosion-resistant special alloy is freely adjustable and preset to ≤ 0.05 mm in the factory. Such setup guarantees optimal cutting results and high operational reliability.

Due to the powerful cutting system, such sewage water lifting units, are suitable for cost-efficient pressure drainage with small pipe diameters and long pressure lines.

Take a look at our high-performance cutting system in action. Simply scan the QR code and start the video.





Dimensioning and design

In order to maintain operationability and efficiency of a lifting unit, it has to be appropriately sized. Site of installation and application in connection with the characteristic parameters such as flow rate, supply height, tank volume and medium to be pumped represent the fundamental characteristics on basis, which the lifting unit is designed of.

On our website in the section "Service" under www.zehnder-pumpen.de, we published our online pump specification tool. This tool is intended to provide you with a fast and easy assistant to select the suitable lifting unit from our product line.

Of course, we are pleased to consult you personally as well. Our competent and kind technical consultants are pleased answering on the phone all your questions around lifting units and pump technology. We offer you solutions for customised units and specific requirements.

Service and maintenance

The Zehnder Pumpen GmbH maintains a comprehensive network of 114 certified customer services in Germany as well as further 20 service partners worldwide. Their trained mechanics provide for the service on-site. In order to guarantee the quality of our service partners, we train them in our factory on a regular basis.

Our customer services are pleased to commission the units on-site in skilled manner. They carry out maintenance as well as repair, too. Spare parts are available for at least 10 years.

FAQ

11 frequently asked questions about our lifting units

1. Why preferring a lifting unit rather than a pump station?

Purchasing a lifting unit is clearly more price-efficient than a pump station. Likewise, the installation is much more easier and significantly cost-saving, since expensive earthwork is not required. Such condition facilitates maintenance and in addition, saves further recurrent expenses.

2. What about the space required for the units?

Our wide-spread product line characterised by very compact sizes and polydirectional inlets offers for each application the appropriate alternative. If, in a special case, none of our lifting units is the adequate one for that particular application, we design a customised solution thanks to our own tank construction department.

3. What, in addition, is required for the installation?

The units are manufactured ready-to-plug-in. All the connecting parts are included in the delivery. The lifting units are fixed on the ground with the supplied bolts to prevent movement of the pump triggered by the starting torque. The check valve(s) is (are) already integrated in the unit or included in the delivery (W 80 and WUZ 100 on option).

4. How the unit is controlled?

The comfort controller ZPS (see p.15) included in the delivery offers, in addition to the complete performance monitoring, all the necessary setting options to match the unit to the local conditions. The measurement of the dynamic pressure with switching points adjustable down to the last millimetre as well as the incorporated acoustic and visual alarms for additional safety, are only two features out of the many advantages.

5. How difficult is maintenance?

Lifting units are installed in a dry environment. In this way, all parts in need of maintenance are easily accessible without having to accept contact with the medium to be supplied. Neither extracting of the pump from the below-ground nor working in it is required. Our lifting units of type Kompaktboy are additionally equipped with a maintenance cover on the check valve to ensure easy access in case of emergency.

6. Is the unit 100% tight?

Our pressure-less collecting tanks are made from first-rate synthetic material whose properties are high toughness, elongation to break and chemical resistance. The special tank design (reinforcing ribs, less straight areas) prevents the tank from "bloating", if the tank happens to get completely filled in case of power failure. The motor is sealed with both a mechanical seal and additional shaft seal.

7. What happens with power failure?

Our controller ZPS outputs an alarm message by means of a mains-independent alarm switchgear in case of mains voltage failure. All the sewage lifting units can be drained in emergency situations with an optional manual membrane pump without power supply required. Depending on the kind of utilization, the tank is properly dimensioned in order to be able receiving incoming sewage water for a short period of time until the fault gets remedied.

8. Is the noise emission inside the house not excessively high?

The powerful pumps drain the collecting tank within few seconds. The low noise emission happens to develop over a short moment only and is hardly to hear in the utility room or basement.

9. Does the unit dispose of sufficient back-up volume?

As for the individual applications, the collecting tanks are properly dimensioned. In case of special requirements, customised designs up to 25 m³ are deliverable.

10. Is a sewage lifting unit prone to obstruction?

A free passage of minimum 50 mm to 100 mm provides for faultless operation of the unit. The heavy-duty cutting system (cutting gap <0.05 mm) built in our lifting units chops solid matters without any problem.

11. Does bad odour develop inside the house?

With sewage lifting units, odour emission are directly discharged to outside through a venting pipe. Waste water lifting units are equipped with an activated carbon filter to avoid bad odour.



Individual solutions

Example Queensbury Place

As an experienced specialist in the area of sewage lifting units, Zehnder Pumps has already accompanied several national and international projects.

The Queensbury Place in Cheam Village, Surrey, England offers 28 modern apartments in a prime location from £335,000. In this exclusive building - modernized by the award winning house builder Chrest Nicholson – highest priority was given to quality and reliability of the implementation of the sewage disposal system. The required sewage lifting unit with a capacity of 12150 litres, provides enough space to secure smooth operation and thereby unrestricted usability of the sanitary facilities - even in case of 24 hours power failure.

Besides the restricted local conditions, also the unproblematic transportability had to be considered for the conception of this special and complex unit. The size of the polyethylene tank with steel reinforcement - 4,21 m x 2,15 m x 1,90 m (LxWxH) – and a total weight of 1,3 tons meet all of the customer's requirements regarding transport and installation. This unit was supplied ready-for-installation with all required accessories like Y-pipe, non-return valves, gate valves and of course our professional pump control unit.

This sewage lifting unit had to be designed, produced, tested and delivered in less than 15 working days to ensure the on-schedule completion of the whole modernisation project. Planning, design and production have been carried out completely by our own to guarantee the high quality level of 'Made in Germany'.



Zehnder Pumpen responds to individual customer needs. Together with the customer, we find the appropriate solution for sewage water disposal.

The entire business procedure at the company location allows us reacting flexibly and rapidly to challenges. Our own tank construction facility enables sizes up to 20,000 l.



The metro Berlin is used by ca. 1,4 mio. passengers every day. We equip a high number of Berlin's metro stations with the latest pump technology.

Zehnder Pumpen lifting units proven a thousand times



Metro station Potsdamer Platz



Main station Amsterdam Centraal



World Trade Center Brussels



European Court of Justice Den Haag



Wiener Prater (Skydiver)



Schloss Cecilienhof in Potsdam



Tropical Island



Al Said Yacht



On our website at www.zehnder-pumpen.de we provide a wide range of information about our lifting units. In addition to technical data sheets for the individual systems, you will also find 3D Pdf's.

Tender texts and CAD data can also be found on our website.

Checklist for the design of lifting units

Contact details*

Company
 Street
 Postal Code, City
 Contact person
 Email
 Phone

Fill in the form and fax it to +49 (0) 37 44 / 52 150 or email it to info@zehnder-pumpen.de

We are happy to answer your questions regarding the design of lifting systems personally on +419 (0) 37 44 / 52 100. Our technical advice will be pleased to help you.

What should be pumped?

sewage containing faeces
 faecal-free waste water
 Condensate from air conditioners or boilers

How much should be pumped?

Building type
 Number of users

Where to pump?

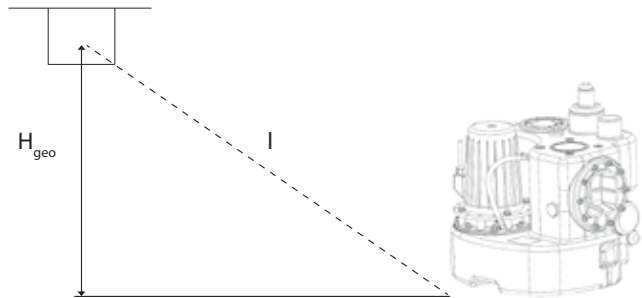

Drainage objects

Quantity

Washbasin, Bidet
 Shower without stopper
 Shower with stopper
 Urinal
 Bathtub
 Kitchen sink
 Dishwasher (household)
 Washing machine up to 6 kg
 Washing machine up to 12 kg
 WC with 4,0/4,5 l cistern
 WC with 6,0 l cistern
 WC with 7,5 l cistern
 WC with 9,0 l cistern
 Ground run DN 50
 Ground run DN 70
 Ground run DN 100

H_{geo} in m

Does the transfer point of the pressure line lie below the installation level of the lifting unit?

Yes (sketch required)
 No

















What should be pumped with?

Simplex unit
 Duplex unit

Comments

.....

*I agree that my data are processed to handle my enquiry. Our data protection declaration is published under www.zehnder-pumpen.de.

Overview application areas														Pressure outlet
floor-standing WC	wall-hung WC	bidet	urinal	wash-basin	shower	bathtub	kitchen sink	dish-washer	washing machine	softening unit	hot water (90°C)	H _{max} [m]	Q _{max} [m ³ /h]	Solids handling [mm]
FAECAL-FREE WASTE WATER														DN 32
				•	•	•	•	•	•	•	short-term	11,00	14,00	10
				•	•	•	•	•	•	•	short-term	11,00	14,00	10
				•	•	•	•	•	•		short-term	11,00	11,00	30
				•	•	•	•	•	•	•	short-term	11,00	11,00	30
				•	•	•	•	•	•		short-term	14,00	10,00	30
				•	•	•	•	•	•		short-term	14,00	10,00	30
				•	•	•	•	•	•	•	short-term	11,00	11,00	30
				•	•	•	•	•	•	•	short-term	11,00	11,00	30
SEWAGE WATER CONTAINING FAECES														DN 32
	•	•	•	•	•	•	•	•	•			11,80	7,50	cutting system
	•	•	•	•	•	•	•	•	•	•	short-term	15,00	49,00	50
	•	•	•	•	•	•	•	•	•	•	short-term	15,00	49,00	50
	•	•	•	•	•	•	•	•	•	•	short-term	39,00	17,00	cutting system
	•	•	•	•	•	•	•	•	•	•	short-term	39,00	17,00	cutting system
	•	•	•	•	•	•	•	•	•	•	short-term	11,00	60,00	80
	•	•	•	•	•	•	•	•	•	•	short-term	11,00	60,00	80
	•	•	•	•	•	•	•	•	•	•	short-term	22,00	165,00	80 / 100
	•	•	•	•	•	•	•	•	•	•	short-term	22,00	165,00	80 / 100



Zehnder Pumpen GmbH
Zwönitzer Straße 19
08344 Grünhain-Beierfeld
Germany

Phone: +49 (0) 3774 52-100
info@zehnder-pumpen.de
www.zehnder-pumpen.de